

REVISIONS			
ISS	ZONE	DESCRIPTION	PER REQUEST\DATE

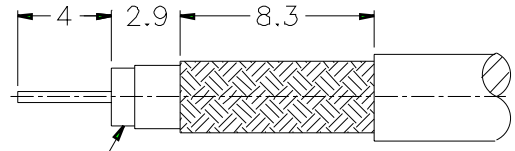

REMOVE FOIL 1mm MIN.
(去除箔襯1mm以上)
) RECOMMENDED
CABLE STRIPPING DIM'S
(建議剝線尺寸)

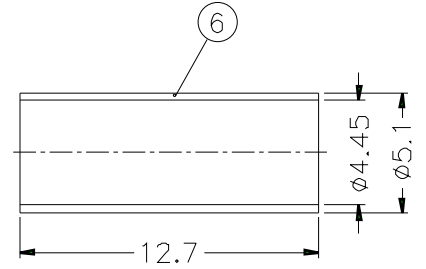
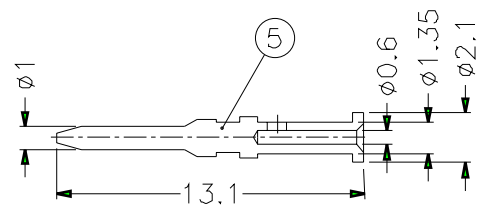
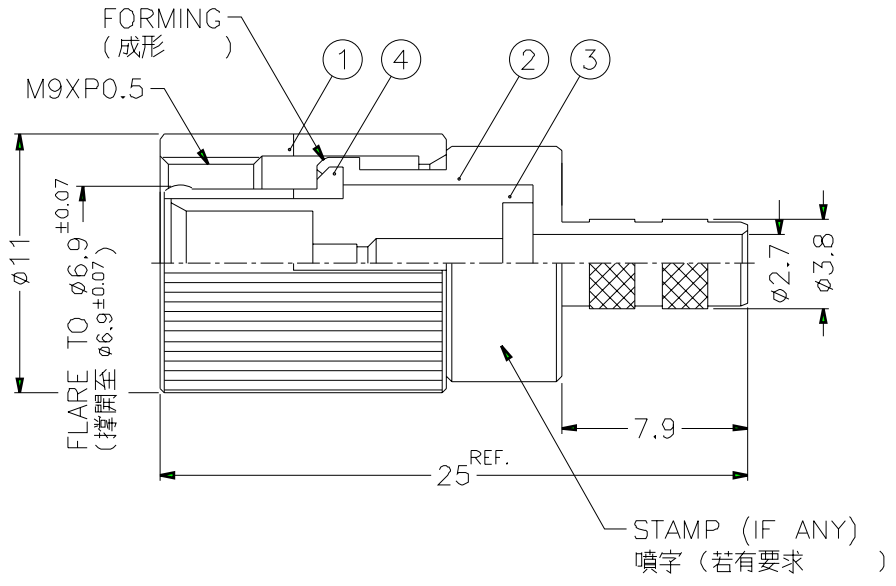

- NOTES: FINISH (PLATING THICKNESS IN MICRO-INCHES)
- BRASS PER QQ-B-626
 - NICKEL PL. 100 MIN. THICK OVER COPPER STRIKE
 - PHOSPHOR BRONZE PER QQ-B-750
 - GOLD PL. 3 MIN. THICK OVER NICKEL PL. 100 MIN. THICK OVER COPPER STRIKE
 - TEFLON MIL-P-19468
 - JIS H 3250, C 2700

- CRIMPED FERRULE
HEX CRIMP SIZE .178"
- CRIMPED CONTACT PIN
SQ. CRIMP SIZE .043"

NO.	DESCRIPTION	MATERIAL	FINISH	Q'TY	DRAWING NO.	SCALE	3/1	ISSUE	A	PART NO.	TITLE
6	FERRULE	NOTE 6	NATURAL	1	FR-51/445X127	DIMENSIONS ARE IN MILLIMETERS UNLESS OTHERWISE SPECIFIED TOLERANCES 0.5-6 = ±0.2 6-30 = ±0.4 30-120 = ±0.6 120-315 = ±1 315-1000 = ±1.6 1000-2000 = ±2.4				161121AAC37NF7F APPROVED DATE 09-17-01' CHECKED DATE 09-17-01' DRAWN DATE 09-17-01'	Amphenol - Kai Jack TAINAN TAIWAN TITLE 1.6/5.6 CRIMP PLUG (FOR FLEX-3/75 CABLE) DRAWING NO. KJ-1561121A3-N/3GT3G-FLEX-3-75 FILE NO. F:\ND\16\1121\AAC\37\7F\NF
5	CONTACT PIN	NOTE 1	NATURAL	1	1561121A1-5-21/06-B						
4	OUTER CONTACT	NOTE 3	NATURAL	1	1561121G1-2						
3	INSULATOR	NOTE 5	NATURAL	1	NS16AAS01A						
2	BODY	NOTE 1	NATURAL	1	1561121A1-2-38/27						
1	SHELL	NOTE 1	NATURAL	1	1561121G1-1-B						