

1 2 3 4 5 6 7 8

REVISIONS		
ISS	ZONE	DESCRIPTION\APPROVED\DATE

業務部

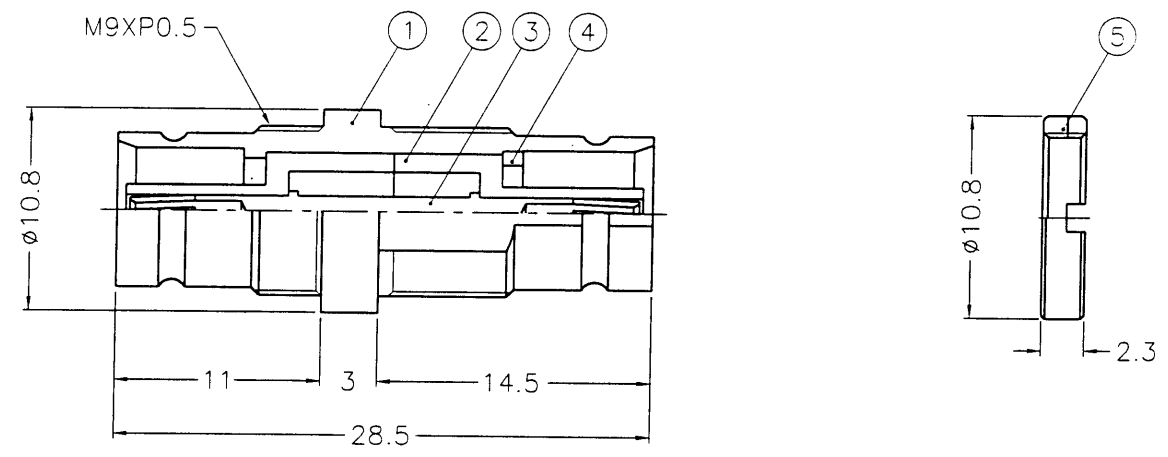

NOTES: FINISH (PLATING THICKNESS IN MICRO-INCHES)
 1. BRASS PER QQ-B-626
 2. NICKEL PL. 100 MIN. THICK OVER COPPER STRIKE
 3. PHOSPHOR BRONZE PER QQ-B-750
 4. GOLD PL. 3 MIN. THICK OVER NICKEL PL. 100 MIN. THICK OVER COPPER STRIKE
 5. TEFLON MIL-P-19468

出圖
87.12.04
R&D

DIMENSIONS ARE IN MILLIMETERS				PART NO.	
UNLESS OTHERWISE SPECIFIED TOLERANCES				APPROVED	
0.5-6	= ±0.2	DATE		12-01-98'	
6-30	= ±0.4	DATE		12-01-98'	
30-120	= ±0.6	DATE		12-01-98'	
120-315	= ±1	DATE		12-01-98'	
315-1000	= ±1.6	DATE		12-01-98'	
1000-2000	= ±2.4	DATE		12-01-98'	

KAI JACK INDUSTRIAL CO., LTD.
TAINAN TAIWAN R.O.C.

TITLE: 1.6/5.6 FEMALE TO FEMALE BULKHEAD ADAPTOR

DRAWING NO. KJ-1567471A1-N/3GT3G-75

FILE NO. F:\DWG\156\7471A1\75\N-3GT3G

NO.	DESCRIPTION	MATERIAL	FINISH	Q'TY	DRAWING NO.
5	NUT	NOTE 1	NOTE 2	1	RN108-9-05X23S
4	LOCK RING	NOTE 1	NOTE 4	1	S931-750-3
3	CONTACT PIN	NOTE 3	NOTE 4	1	1567471A1-3
2	INSULATOR	NOTE 5	NATURAL	2	1567471A1-2
1	BODY	NOTE 1	NOTE 4	1	1567471A1-1

1 2 3 4 5 6 7 8 81k6-2000