

REVISIONS			
ISS	ZONE	DESCRIPTION\PER REQUEST\DATE	
B	B-3	NO.8 WAS CHANGED\RD-DM91082201W\08-22-02'	

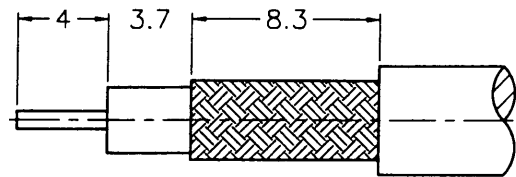

RECOMMENDED  
CABLE STRIPPING DIM'S  
(建議剝線尺寸)



F

F

E

E

D

D

C

C

B

B

A

A

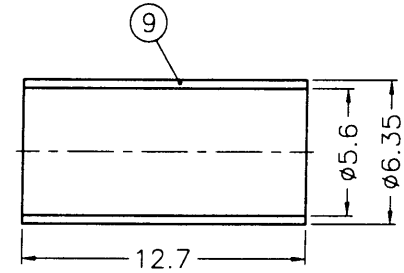
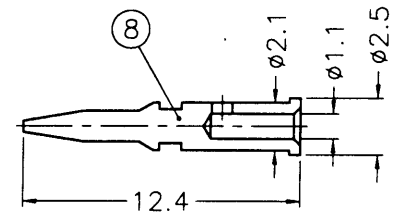
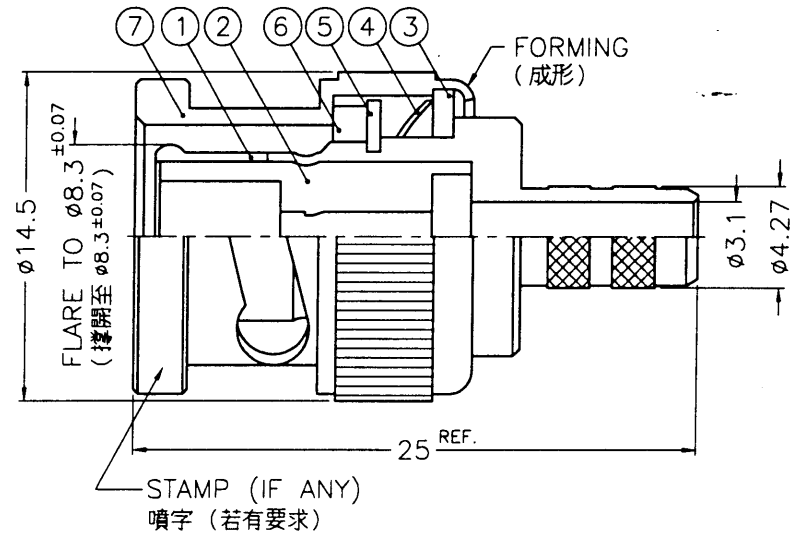

- NOTES: FINISH (PLATING THICKNESS IN MICRO-INCHES)
1. BRASS PER QQ-B-626
  2. BRASS PER QQ-B-613
  3. NICKEL PL. 100 MIN. THICK OVER COPPER STRIKE
  4. NICKEL PL. 200 MIN. THICK OVER COPPER STRIKE
  5. GOLD PL. 3 MIN. THICK OVER NICKEL PL. 100 MIN. THICK OVER COPPER STRIKE
  6. JIS H 3250, C 2600

1. CRIMPED FERRULE  
HEX CRIMP SIZE .213"
2. CRIMPED CONTACT PIN  
HEX CRIMP SIZE .068"



NO.	DESCRIPTION	MATERIAL	FINISH	Q'TY	DRAWING NO.
9	FERRULE			1	FR-635/56X127
8	CONTACT PIN			1	B50000-8-25/11
7	SHELL			1	B50000-1-B
6	GASKET	RUBBER	RED	1	GS-115/8X15
5	RETAINER RING			1	B50000-5
4	SPRING	SK5		1	B50000-6
3	WASHER			1	WS-128/9X08
2	INSULATOR	DELTRIN	NATURAL	1	B50000-3-50-A
1	BODY			1	B50000-2-427/31

DIMENSIONS ARE IN MILLIMETERS				PART NO.	
UNLESS OTHERWISE SPECIFIED TOLERANCES				APPROVED	DATE
0.5-6	= ±0.2			<i>Mark C</i>	08-22-02'
6-30	= ±0.4			CHECKED	DATE
30-120	= ±0.6			<i>Karl J.</i>	08-22-02'
120-315	= ±1			DRAWN	DATE
315-1000	= ±1.6			<i>Angela W</i>	08-22-02'
1000-2000	= ±2.4			FILE NO. F:\DWG\B\1121A1\223U-50\ND3G	

Amphenol - Kai Jack	
TAINAN TAIWAN	
TITLE	BNC CRIMP PLUG (FOR RG-55/U, 142A/U, 400/U, 223/U)
DRAWING NO.	KJ-B1121A1-ND3G-223U-50
ITEM NO.	011121AAA26ND5F

7RD-DR 15297 8