

REVISIONS		
ISS	ZONE	DESCRIPTION \ APPROVED \ DATE

業務部

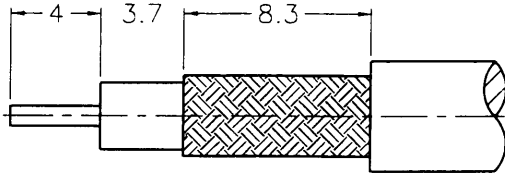

RECOMMENDED CABLE STRIPPING DIM'S

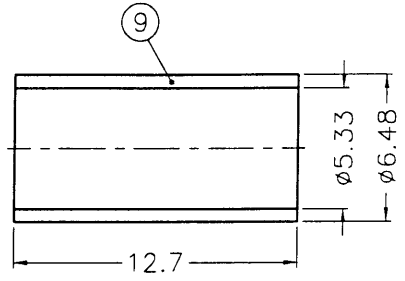
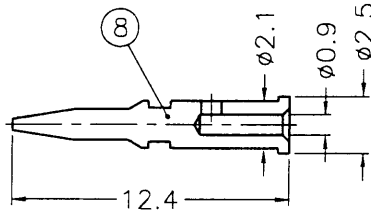
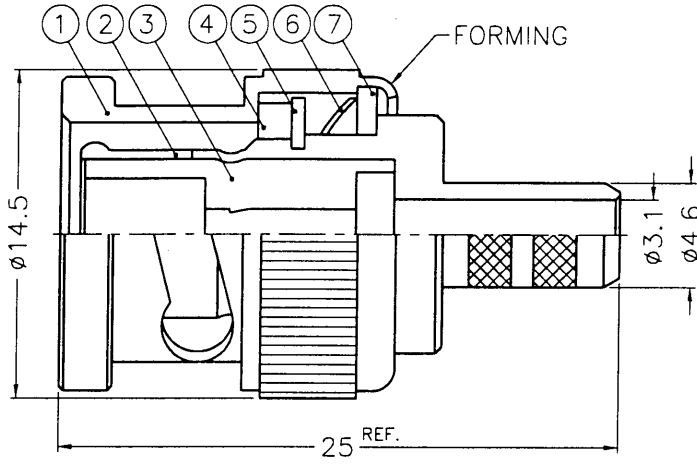

NOTES: FINISH (PLATING THICKNESS IN MICRO-INCHES)
 1. BRASS PER QQ-B-626
 2. BRASS PER QQ-B-613
 3. NICKEL PL. 100 MIN. THICK OVER COPPER STRIKE
 4. NICKEL PL. 200 MIN. THICK OVER COPPER STRIKE
 5. GOLD PL. 3 MIN. THICK OVER NICKEL PL. 100 MIN. THICK OVER COPPER STRIKE

出圖
87.8.17
R&D

NO.	DESCRIPTION	MATERIAL	FINISH	Q'TY	DRAWING NO.
9	FERRULE	COPPER	NOTE 3	1	FR-648/533X 127C
8	CONTACT PIN	NOTE 1	NOTE 5	1	B50000-8-25/09
7	WASHER	NOTE 2	NOTE 3	1	WS-128/9X08
6	SPRING	SK5	NOTE 4	1	B50000-6
5	RETAINER RING	NOTE 1	NOTE 3	1	B50000-5
4	GASKET	RUBBER	RED	1	GS-115/BX15
3	INSULATOR	DELTRIN	NATURAL	1	B50000-3-50-A
2	BODY	NOTE 1	NOTE 3	1	B50000-2-46/31
1	SHELL	NOTE 1	NOTE 3	1	B50000-1-B

DIMENSIONS ARE IN MILLIMETERS
 UNLESS OTHERWISE SPECIFIED TOLERANCES
 0.5-6 = ±0.2
 6-30 = ±0.4
 30-120 = ±0.6
 120-315 = ±1
 315-1000 = ±1.6
 1000-2000 = ±2.4

PART NO.	
APPROVED	DATE 08-14-98'
CHECKED	DATE 08-14-98'
DRAWN	DATE 08-14-98'

KAI JACK INDUSTRIAL CO., LTD. TAINAN TAIWAN R.O.C.	
TITLE	BNC CRIMP PLUG
DRAWING NO.	KJ-B1121A1-ND3G-58U-50
FILE NO.	F:\DWG\B\1121A1\58U-50\ND3G

F
E
D
C
B
A

F
E
D
C
B
A