

REVISIONS		
ISS	ZONE	DESCRIPTION\PER REQUEST\DATE

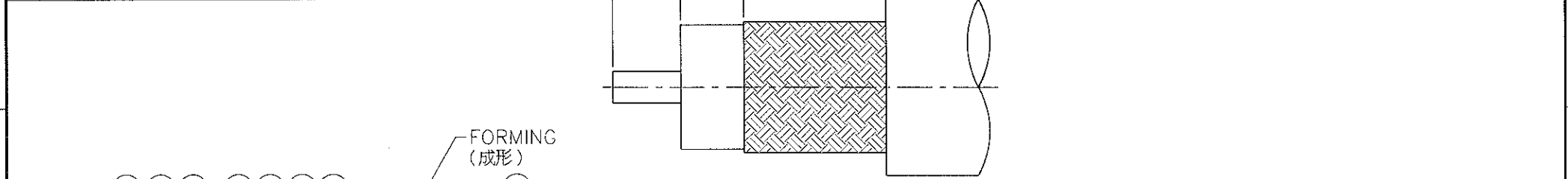

FORMING (成形)

RECOMMENDED CABLE STRIPPING DIM'S (建議剝線尺寸)

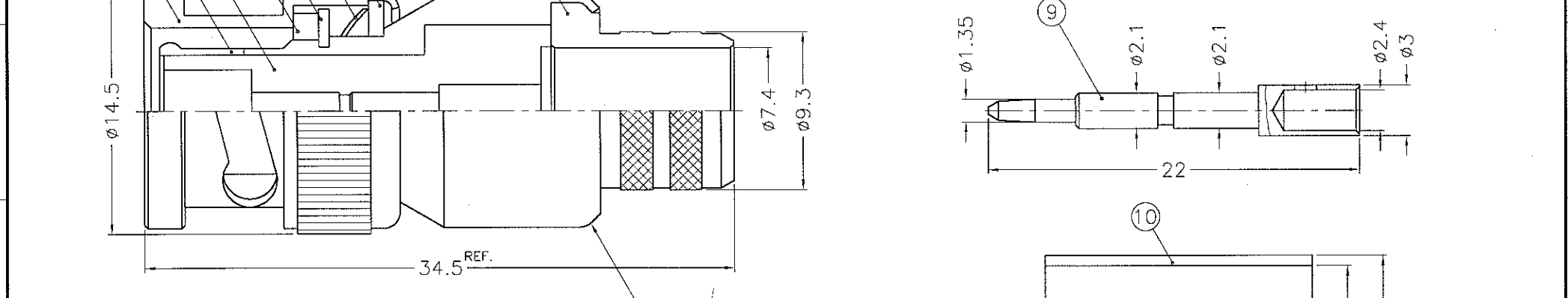

FORMING (成形)

- NOTES: FINISH (PLATING THICKNESS IN MICRO-INCHES)
- BRASS PER QQ-B-626
 - BRASS PER QQ-B-613
 - NICKEL PL. 100 MIN. THICK OVER COPPER STRIKE
 - NICKEL PL. 200 MIN. THICK OVER COPPER STRIKE
 - GOLD PL. 3 MIN. THICK OVER NICKEL PL. 100 MIN. THICK OVER COPPER STRIKE
 - TEFLON MIL-P-19468
 - JIS H 3250, C 2700

10	FERRULE	NOTE 7	NOTE 3	1	FR-124/112X158
9	CONTACT PIN	NOTE 1	NOTE 5	1	B5201-13-3/24
8	WASHER	NOTE 2	NOTE 3	1	WS-128/9X08
7	SPRING	SK5	NOTE 4	1	B50000-6
6	RETAINER RING	NOTE 1	NOTE 3	1	B50000-5
5	GASKET	RUBBER	RED	1	GS-115/8X15
4	BARREL	NOTE 1	NOTE 3	1	N5000-3-93/74
3	INSULATOR	NOTE 6	NATURAL	1	B5201-3T-50
2	BODY	NOTE 1	NOTE 3	1	B1121A6-2
1	SHELL	NOTE 1	NOTE 3	1	B50000-1-B
NO.	DESCRIPTION	MATERIAL	FINISH	Q'TY	DRAWING NO.

DIMENSIONS ARE IN MILLIMETERS
UNLESS OTHERWISE SPECIFIED TOLERANCES

0.5-6 = ±0.2
6-30 = ±0.4
30-120 = ±0.6
120-315 = ±1
315-1000 = ±1.6
1000-2000 = ±2.4

PART NO.	
APPROVED	DATE 06-24-99'
CHECKED	DATE 06-24-99'
DRAWN	DATE 06-24-99'

KAI JACK INDUSTRIAL CO., LTD.
TAINAN TAIWAN R.O.C.

TITLE: BNC CRIMP PLUG

DRAWING NO. KJ-B1121A6-NT3G-214U-50

FILE NO. F:\DWG\B\1121A6\214U-50\NT3G

8825574