

REVISIONS			
ISS	ZONE	DESCRIPTION\PER	REQUES\DATE

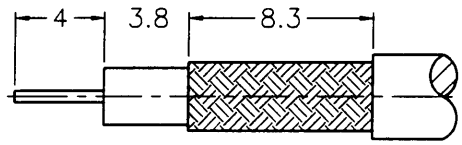

RECOMMENDED
CABLE STRIPPING DIM'S
(建議剝線尺寸)

業務部

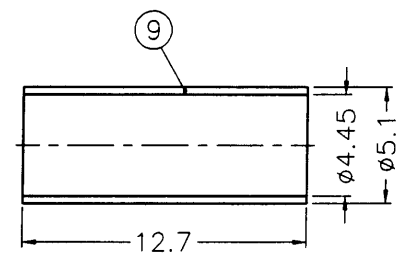
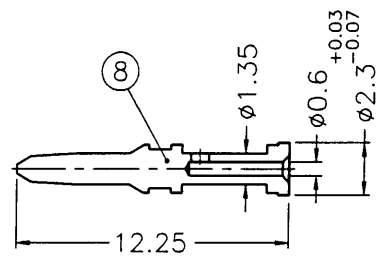
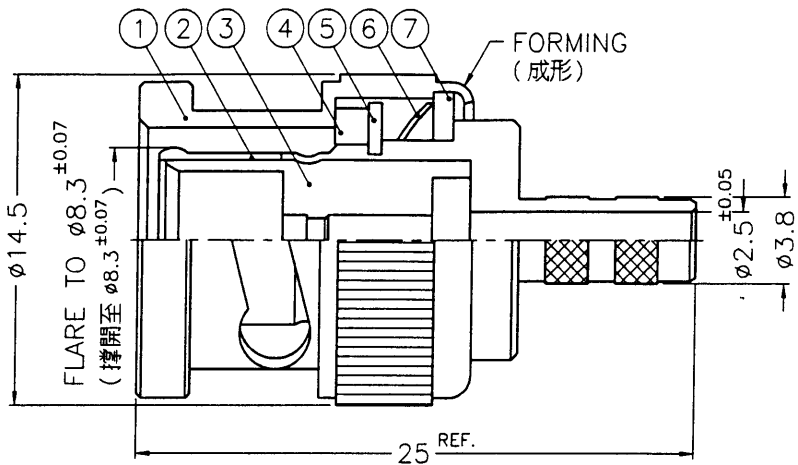

- NOTES: FINISH (PLATING THICKNESS IN MICRO-INCHES)
- BRASS PER QQ-B-626
 - BRASS PER QQ-B-613
 - NICKEL PL. 100 MIN. THICK OVER COPPER STRIKE
 - NICKEL PL. 200 MIN. THICK OVER COPPER STRIKE
 - GOLD PL. 3 MIN. THICK OVER NICKEL PL. 100 MIN. THICK OVER COPPER STRIKE
 - TEFLON MIL-P-19468
 - JIS H 3250, C 2700

出圖
2007.2.08
設計部

- CRIMPED FERRULE
HEX CRIMP SIZE .178"
- CRIMPED CONTACT PIN
HEX CRIMP SIZE .043"

NO.	DESCRIPTION	MATERIAL	FINISH	Q'TY	DRAWING NO.
9	FERRULE	NOTE 7	NOTE 3	1	FR-51/445X127
8	CONTACT PIN	NOTE 1	NOTE 5	1	B1121C8-8-23/06
7	WASHER	NOTE 2	NOTE 3	1	WS-128/9X08
6	SPRING	SK5	NOTE 4	1	B50000-6
5	RETAINER RING	NOTE 1	NOTE 3	1	B50000-5
4	GASKET	RUBBER	RED	1	GS-115/8X15
3	INSULATOR	NOTE 6	NATURAL	1	B1121A8-004-3T-75
2	BODY	NOTE 1	NOTE 3	1	B50000-2-38/25
1	SHELL	NOTE 1	NOTE 3	1	B50000-1-B

DIMENSIONS ARE IN MILLIMETERS UNLESS OTHERWISE SPECIFIED TOLERANCES				PART NO.	
0.5-6	= ±0.2	APPROVED		DATE	
6-30	= ±0.4	CHECKED		DATE	
30-120	= ±0.6	DRAWN		DATE	
120-315	= ±1				
315-1000	= ±1.6				
1000-2000	= ±2.4				

Amphenol - Kai Jack	
TAINAN TAIWAN	
TITLE	BNC CRIMP PLUG (FOR FLEX-3/75 CABLE)
DRAWING NO.	KJ-B1121A8-004-NT3G-75
FILE NO.	F:\DWG\B\1121A8\004\75\NT3G

F
E
D
C
B
A

F
E
D
C
B
A