

REVISIONS			
ISS	ZONE	DESCRIPTION\PER REQUEST\DATE	
A1	A-1	NO.6 WAS CHANGED\N/A\01-23-03'	

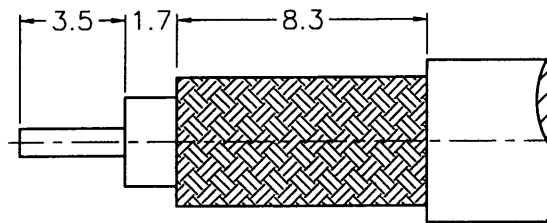

RECOMMENDED
CABLE STRIPPING DIM'S
(建議剝線尺寸)

SALES

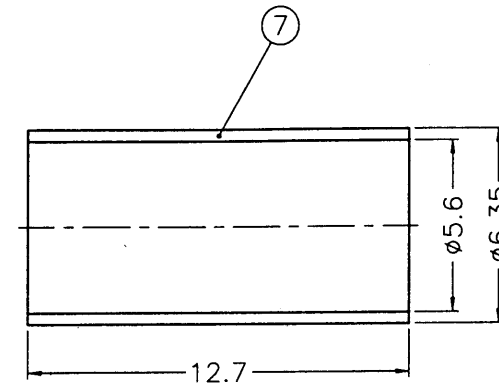
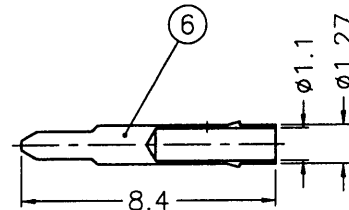
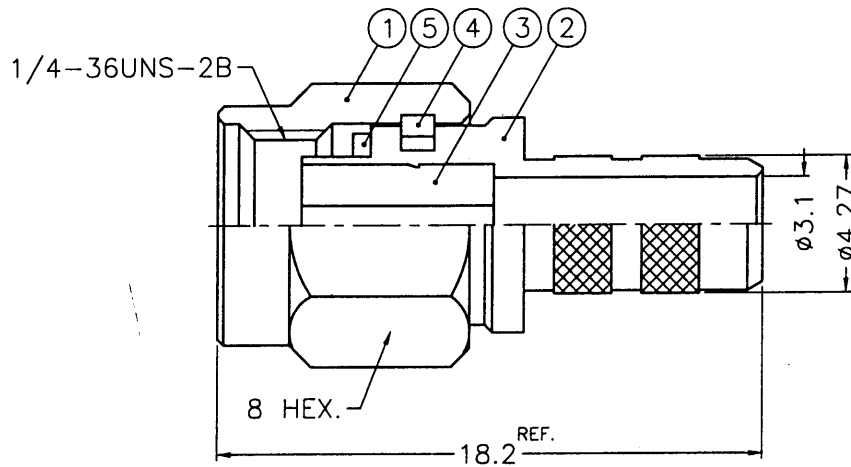

NOTES: FINISH (PLATING THICKNESS IN MICRO-INCHES)

1. BRASS PER QQ-B-626
2. GOLD PL. 3 MIN. THICK OVER NICKEL PL. 100 MIN. THICK OVER COPPER STRIKE
3. BERYLLIUM COPPER PER QQ-C-530
4. GOLD PL. 50 MIN. THICK OVER NICKEL PL. 100 MIN. THICK OVER COPPER STRIKE
5. TEFLON MIL-P-19468
6. JIS H 3250, C 2600

ISSUED
2003. 2. 10
R&D

1. CRIMPED FERRULE
HEX. CRIMP SIZE .213"
2. CONTACT PIN TO SOLDER

NO.	DESCRIPTION	MATERIAL	FINISH	Q'TY	DRAWING NO.	SCALE	4/1	ISSUE	A1	FILE NO.	F:\DWG\SMA\1111A1\223U-50\3GT50G	
7	FERRULE	NOTE 6	NOTE 2	1	FR-635/56X127	DIMENSIONS ARE IN MILLIMETERS UNLESS OTHERWISE SPECIFIED TOLERANCES 0.5-6 = ±0.2 6-30 = ±0.4 30-120 = ±0.6 120-315 = ±1 315-1000 = ±1.6 1000-2000 = ±2.4				PART NO.		
6	CONTACT PIN	NOTE 1	NOTE 4	1	SMA5000-6-127/11		APPROVED	<i>gackey</i>	DATE	01-23-03'		
5	GASKET	SILICONE	RED	1	GS-6/43X06		CHECKED	<i>Ken</i>	DATE	01-23-03'		
4	RETAINER RING	NOTE 3	NATURAL	1	SMA5000-4-B		DRAWN	<i>Ken</i>	DATE	01-23-03'		
3	INSULATOR	NOTE 5	NATURAL	1	SMA5000-3T-50						TITLE	SMA CRIMP PLUG (FOR RG-55/U,142A/U,223/U,400/U)
2	BODY	NOTE 1	NOTE 2	1	SMA5000-2-427/31						DRAWING NO.	SMA1111A1-3GT50G-223U-50
1	SHELL	NOTE 1	NOTE 2	1	SMA5000-1-C						ITEM NO.	111111AAA26GA5F

Amphenol
Danbury, CT, USA - Tainan, Taiwan - Shenzhen, China

7RD-DR 16926 8