

1 2 3 4 5 6 7 8

REVISIONS			
ISS	ZONE	DESCRIPTION\PER REQUEST\DATE	

F

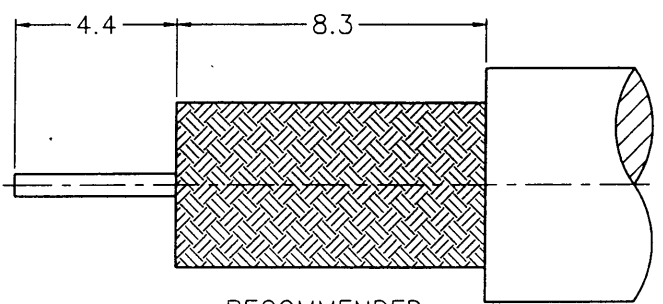
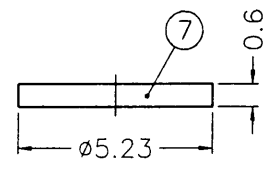

RECOMMENDED
CABLE STRIPPING DIM'S
(建議剝線尺寸)

E

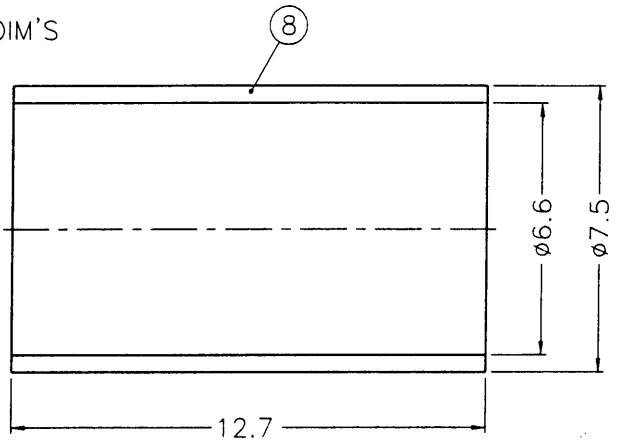
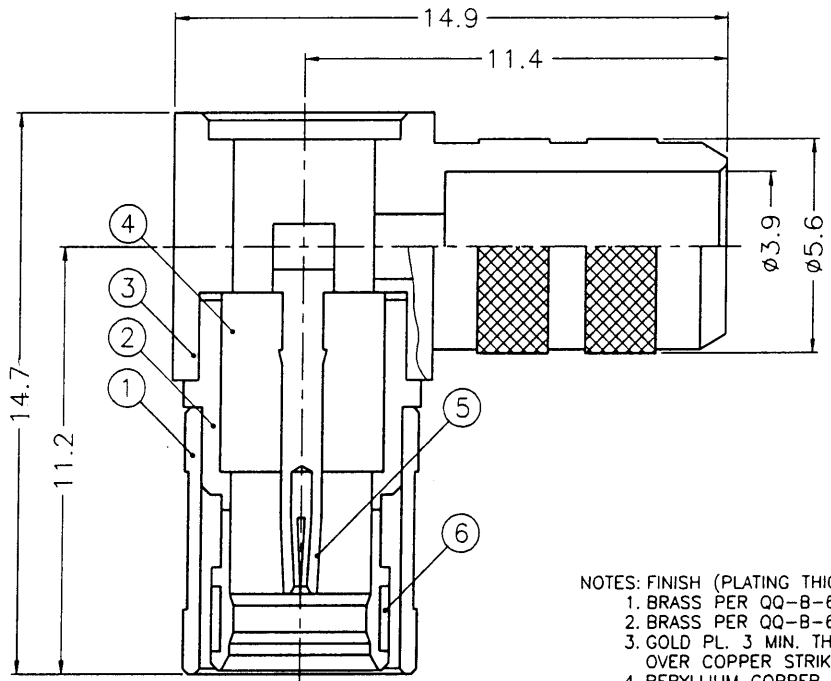

D

C

B

NOTES: FINISH (PLATING THICKNESS IN MICRO-INCHES)
 1. BRASS PER QQ-B-626
 2. BRASS PER QQ-B-613
 3. GOLD PL. 3 MIN. THICK OVER NICKEL PL. 100 MIN. THICK OVER COPPER STRIKE
 4. BERYLLIUM COPPER PER QQ-C-530
 5. GOLD PL. 30 MIN. THICK OVER NICKEL PL. 100 MIN. THICK OVER COPPER STRIKE
 6. TEFLON MIL-P-19468
 7. JIS H 3250, C 2700

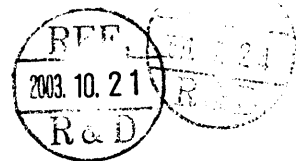

- 1. CRIMPED FERRULE
HEX CRIMP SIZE .255"
- 2. CONTACT PIN TO SOLDER

A

8	FERRULE	NOTE 7	NOTE 3	1	FR-75/66X127
7	COVER	NOTE 2	NOTE 3	1	CV-523X06-T
6	RETAINER RING	NOTE 4	NATURAL	1	SMB5000-6
5	CONTACT PIN	NOTE 4	NOTE 5	1	SMB5090-5-B
4	INSULATOR	NOTE 6	NATURAL	1	SMB6112AA-4T-75
3	BARREL	NOTE 1	NOTE 3	1	SMB1112AA-3-56 /39
2	BODY	NOTE 1	NOTE 3	1	SMB6112AA-2-75
1	SHELL	NOTE 1	NOTE 3	1	SMB5000-1

DIMENSIONS ARE IN MILLIMETERS			
UNLESS OTHERWISE SPECIFIED TOLERANCES			
0.5-6	=	±0.2	
6-30	=	±0.4	
30-120	=	±0.6	
120-315	=	±1	
315-1000	=	±1.6	
1000-2000	=	±2.4	

PART NO.	
APPROVED	DATE
CHECKED	DATE
DRAWN	DATE

Amphenol - Kai Jack	
TAINAN TAIWAN	
TITLE	MINI 75 OHM SMB R/A CRIMP PLUG (FOR RG-59A/U,59B/U CABLE)
DRAWING NO.	KJ-SMB6112AH-3GT30G-59U-75
FILE NO.	F:\DWG\SMB\6112AH\59U-75\3GT30G

1 2 3 4 5 6 7 8