

REVISIONS		
ISS	ZONE	DESCRIPTION\PER REQUEST\DATE
A1	A-3	NO.1 ~ 3 AND NO.5 ~ 9'S DRAWING NO. WERE CHANGED\N/A\08-06-02'

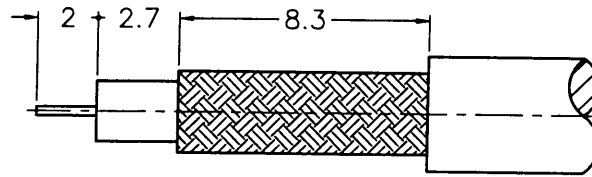

RECOMMENDED
CABLE STRIPPING DIM'S
(建議剝線尺寸)

SALES

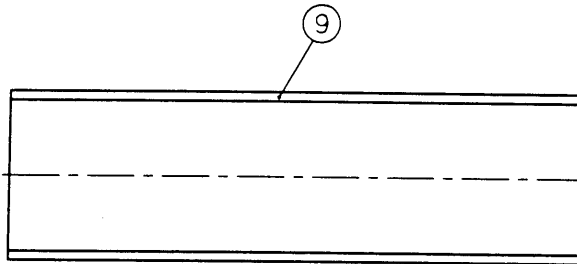
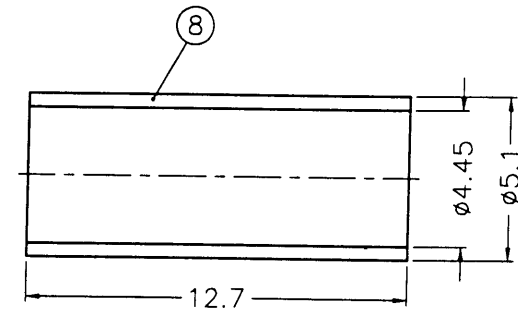
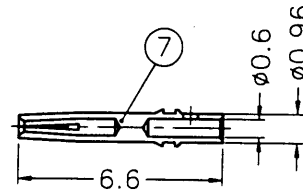
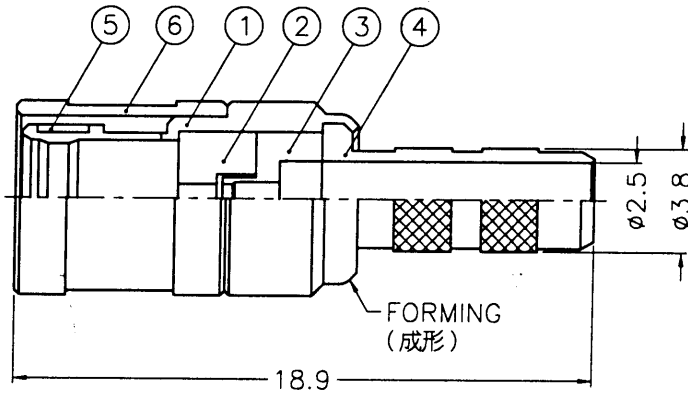

NOTES: FINISH (PLATING THICKNESS IN MICRO-INCHES)

1. BRASS PER QQ-B-626
2. GOLD PL. 3 MIN. THICK OVER NICKEL PL. 100 MIN. THICK OVER COPPER STRIKE
3. BERYLLIUM COPPER PER QQ-C-530
4. GOLD PL. 30 MIN. THICK OVER NICKEL PL. 100 MIN. THICK OVER COPPER STRIKE
5. TEFLON MIL-P-19468
6. JIS H 3250, C 2600

ISSUED
2002. 8. 08
R&D

1. CRIMPED FERRULE
HEX CRIMP SIZE .178"
2. CONTACT PIN TO SOLDER

9	HEAT SHRINK TUBING			1	HT-56/5X193
8	FERRULE	NOTE 6	NOTE 2	1	FR-51/445X127
7	CONTACT PIN	NOTE 3	NOTE 4	1	SMB6121B2-5-096/06-D
6	SHELL	NOTE 1	NOTE 2	1	SMB5000-1
5	RETAINER RING	NOTE 3	NATURAL	1	SMB5000-6
4	BARREL	NOTE 1	NOTE 2	1	BRO0ABN05A
3	INSULATOR	NOTE 5	NATURAL	1	SMB1121AA-3T-735A
2	INSULATOR	NOTE 5	NATURAL	1	SMB6121AA-2T-75
1	BODY	NOTE 1	NOTE 2	1	SMB6121AA-1-75

DIMENSIONS ARE IN MILLIMETERS				PART NO.	
UNLESS OTHERWISE SPECIFIED TOLERANCES				APPROVED	DATE
0.5-6	= ±0.2			<i>Loai</i>	08-06-02'
6-30	= ±0.4			CHECKED	DATE
30-120	= ±0.6			<i>Loai</i>	08-06-02'
120-315	= ±1			DRAWN	DATE
315-1000	= ±1.6			<i>Loai</i>	08-06-02'
1000-2000	= ±2.4			FILE NO.	F:\DWG\SMB\6121AA\FLEX-3\75\3GT30G

Amphenol - Kai Jack
TAINAN TAIWAN

TITLE	MINI 75 OHM SMB CRIMP PLUG (FOR FLEX-3 CABLE)
DRAWING NO.	KJ-SMB6121AA-3GT30G-FLEX-3-75
ITEM NO.	126111AAC37GE7F