

1 2 3 4 5 6 7 8

REVISIONS		
ISS	ZONE	DESCRIPTION\PER REQUEST\DATE

業務部

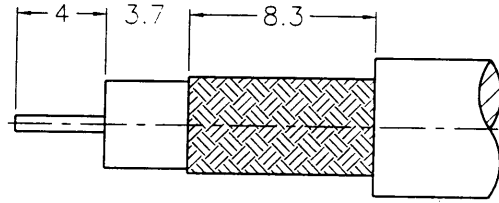

RECOMMENDED  
CABLE STRIPPING DIM'S

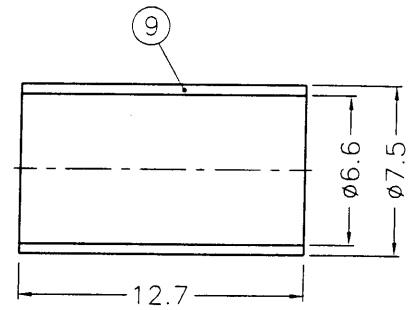
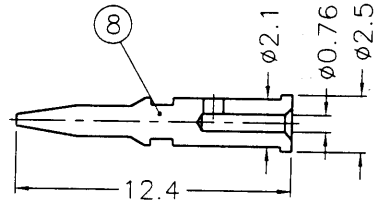
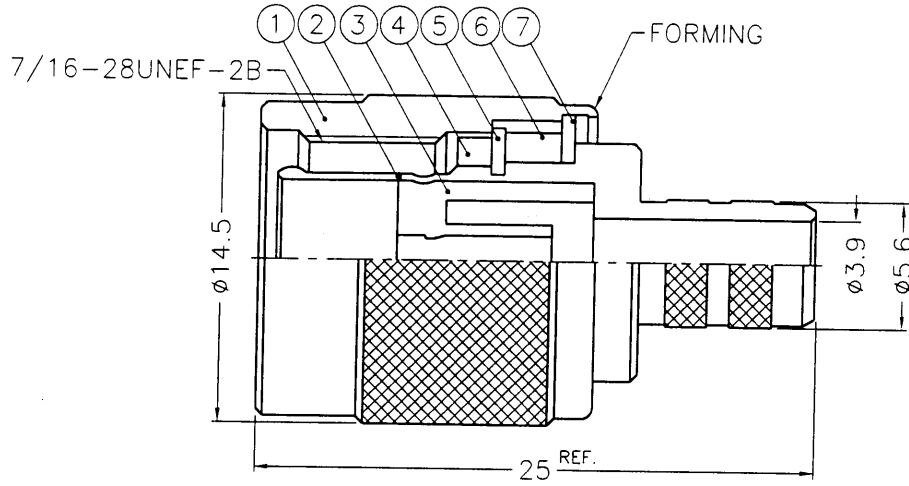

- NOTES: FINISH (PLATING THICKNESS IN MICRO-INCHES)
1. BRASS PER QQ-B-626
  2. BRASS PER QQ-B-613
  3. NICKEL PL. 100 MIN. THICK OVER COPPER STRIKE
  4. GOLD PL. 3 MIN. THICK OVER NICKEL PL. 100 MIN. THICK OVER COPPER STRIKE
  5. JIS H 3250, C 2700



9	FERRULE	NOTE 1	NOTE 5	1	FR-75/66X127
8	CONTACT PIN	NOTE 1	NOTE 4	1	B50000-8-25/076
7	WASHER	NOTE 2	NOTE 3	1	WS-128/9X08
6	RING	DELIN	NATURAL	1	T50000-6-A
5	RETAINER RING	NOTE 1	NOTE 3	1	B50000-5
4	GASKET	RUBBER	RED	1	GS-105/8X15
3	INSULATOR	DELIN	NATURAL	1	B50000-3-75-A
2	BODY	NOTE 1	NOTE 3	1	B50000-2-56/39
1	SHELL	NOTE 1	NOTE 3	1	T50000-1-B
NO.	DESCRIPTION	MATERIAL	FINISH	Q'TY	DRAWING NO.

DIMENSIONS ARE IN MILLIMETERS			
UNLESS OTHERWISE SPECIFIED TOLERANCES			
0.5-6	=	±0.2	
6-30	=	±0.4	
30-120	=	±0.6	
120-315	=	±1	
315-1000	=	±1.6	
1000-2000	=	±2.4	
SCALE	3/1	ISSUE	A

PART NO.	
APPROVED	DATE 03-08-99'
CHECKED	DATE 03-08-99'
DRAWN	DATE 03-08-99'

<b>KAI JACK INDUSTRIAL CO., LTD.</b> TAINAN TAIWAN R.O.C.	
TITLE TNC CRIMP PLUG	
DRAWING NO. KJ-T1121A1-ND3G-59U-75	
FILE NO. F:\DWG\T\1121A1\59U-75\ND3G	

F  
E  
D  
C  
B  
A

F  
E  
D  
C  
B  
A

1 2 3 4 5 6 7 8