

業務部

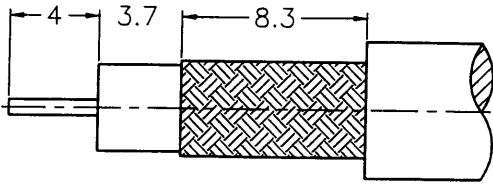

RECOMMENDED CABLE STRIPPING DIM'S
(建議剝線尺寸)

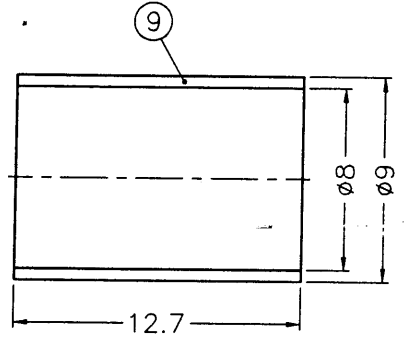
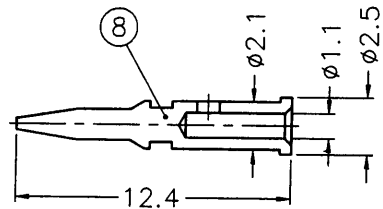
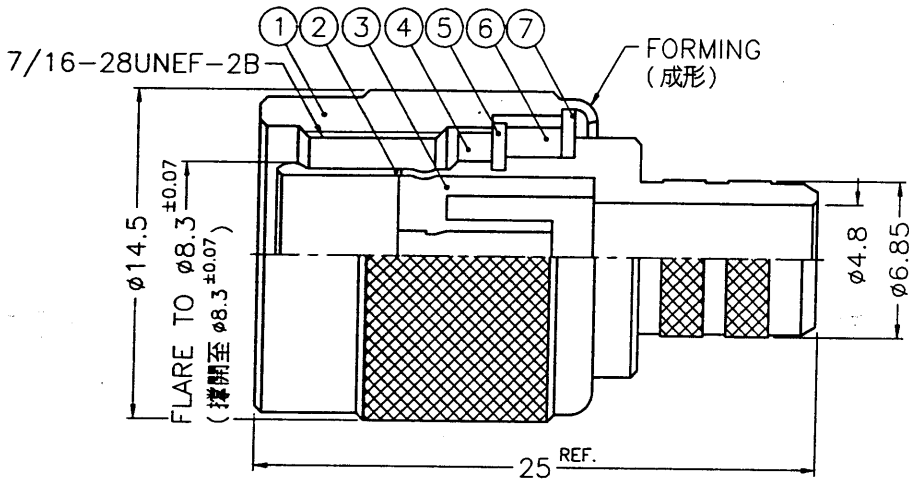

- NOTES: FINISH (PLATING THICKNESS IN MICRO-INCHES)
- BRASS PER QQ-B-626
 - BRASS PER QQ-B-613
 - NICKEL PL. 100 MIN. THICK OVER COPPER STRIKE
 - GOLD PL. 3 MIN. THICK OVER NICKEL PL. 100 MIN. THICK OVER COPPER STRIKE
 - JIS H 3250, C 2700

- CRIMPED FERRULE
HEX CRIMP SIZE .324"
- CRIMPED CONTACT PIN
HEX CRIMP SIZE .068"

出圖
89.6.13
設計部

NO.	DESCRIPTION	MATERIAL	FINISH	Q'TY	DRAWING NO.
9	FERRULE		NOTE 5	NOTE 3	1 FR-9/8X127
8	CONTACT PIN		NOTE 1	NOTE 4	1 B50000-8-25/11
7	WASHER		NOTE 2	NOTE 3	1 WS-128/9X08
6	RING	DELRIN	NATURAL		1 T50000-6-A
5	RETAINER RING		NOTE 1	NOTE 3	1 B50000-5
4	GASKET	RUBBER	RED		1 GS-105/8X15
3	INSULATOR	DELRIN	NATURAL		1 B50000-3-75-A
2	BODY		NOTE 1	NOTE 3	1 B50000-2-685/48
1	SHELL		NOTE 1	NOTE 3	1 T50000-1-B

DIMENSIONS ARE IN MILLIMETERS		PART NO.	
UNLESS OTHERWISE SPECIFIED TOLERANCES		APPROVED <i>[Signature]</i> DATE 06-10-00'	
0.5-6 = ±0.2		CHECKED <i>[Signature]</i> DATE 06-10-00'	
6-30 = ±0.4		DRAWN <i>[Signature]</i> DATE 06-10-00'	
30-120 = ±0.6			
120-315 = ±1			
315-1000 = ±1.6			
1000-2000 = ±2.4			
SCALE 3/1	ISSUE A		

Amphenol - Kai Jack TAINAN TAIWAN	
TITLE	TNC CRIMP PLUG
DRAWING NO.	KJ-T1121A1-ND3G-6U-75
FILE NO.	F:\DWG\T\1121A1\6U-75\ND3G