

1 2 3 4 5 6 7 8

REVISIONS		
ISS	ZONE	DESCRIPTION\PER REQEST\DATE

業務部

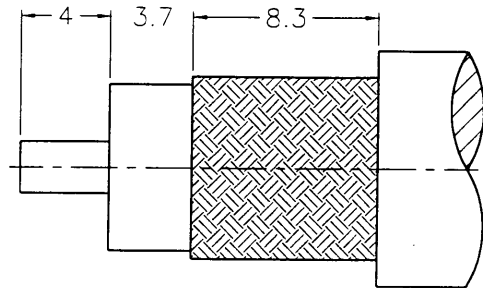

RECOMMENDED
CABLE STRIPPING DIM'S

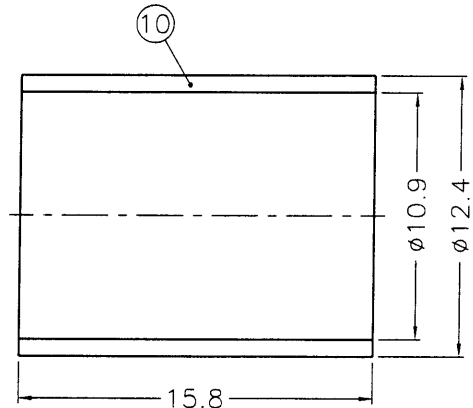
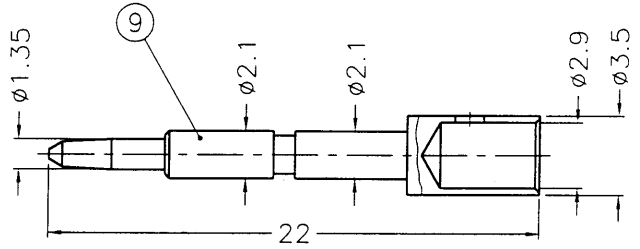
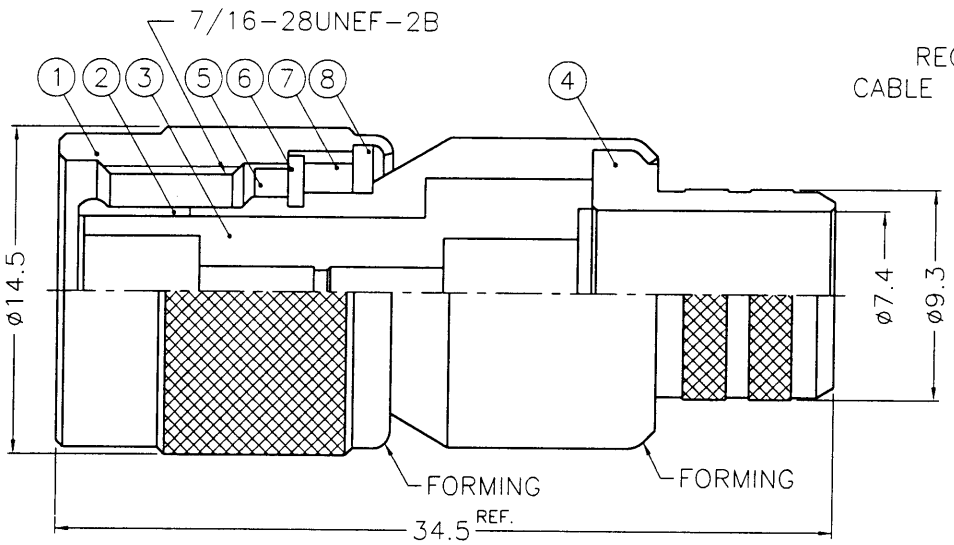

NOTES: FINISH (PLATING THICKNESS IN MICRO-INCHES)

1. BRASS PER QQ-B-626
2. BRASS PER QQ-B-613
3. NICKEL PL. 100 MIN. THICK OVER COPPER STRIKE
4. GOLD PL. 3 MIN. THICK OVER NICKEL PL. 100 MIN. THICK OVER COPPER STRIKE
5. TEFLON MIL-P-19468
6. JIS H 3250, C 2700

NO.	DESCRIPTION	MATERIAL	FINISH	Q'TY	DRAWING NO.
10	FERRULE			1	FR-124/109X158
9	CONTACT PIN			1	B5201-13-35/29
8	WASHER			1	WS-128/9X08
7	RING	DELTRIN	NATURAL	1	T50000-6-A
6	RETAINER RING			1	B50000-5
5	GASKET	RUBBER	RED	1	GS-105/8X15
4	BARREL			1	N5000-3-93/74
3	INSULATOR			1	B5201-3T-50-89913
2	BODY			1	B1121A6-2
1	SHELL			1	T50000-1-B

DIMENSIONS ARE IN MILLIMETERS
UNLESS OTHERWISE SPECIFIED TOLERANCES

0.5-6	= ±0.2
6-30	= ±0.4
30-120	= ±0.6
120-315	= ±1
315-1000	= ±1.6
1000-2000	= ±2.4

PART NO.	
APPROVED	DATE
CHECKED	DATE
DRAWN	DATE

<p>KAI JACK INDUSTRIAL CO., LTD. TAINAN TAIWAN R.O.C.</p>	TITLE
	DRAWING NO.
	FILE NO.

B
D
E
F
A

F
E
D
C
B
A

1 2 3 4 5 6 7 8

87-20967