

REVISIONS		
ISS	ZONE	DESCRIPTION\PER REQUEST\DATE
B	B-3	NO.11, NO.12, NO.13 AND NO.14 WERE CHANGED\RD -DM92012402W\01-24-03'

SALES

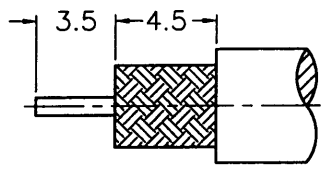

1. CONTACT PIN TO SOLDER

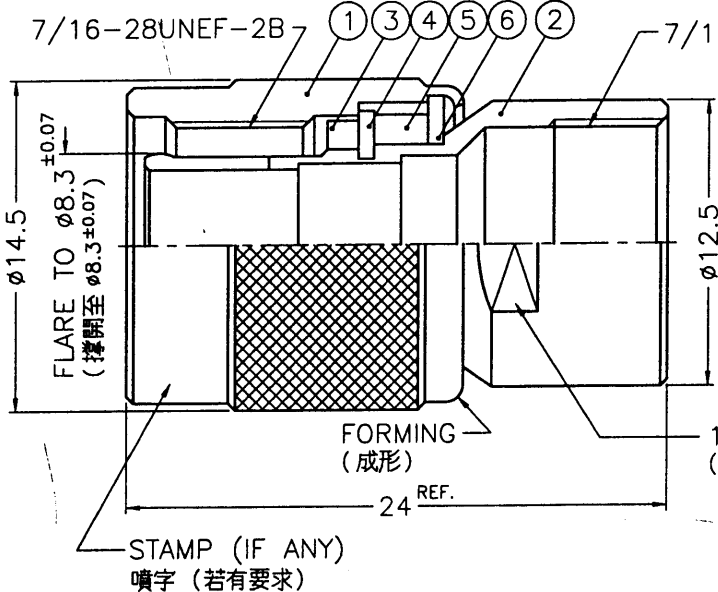

RECOMMENDED  
CABLE STRIPPING DIM'S  
(建議剝線尺寸)

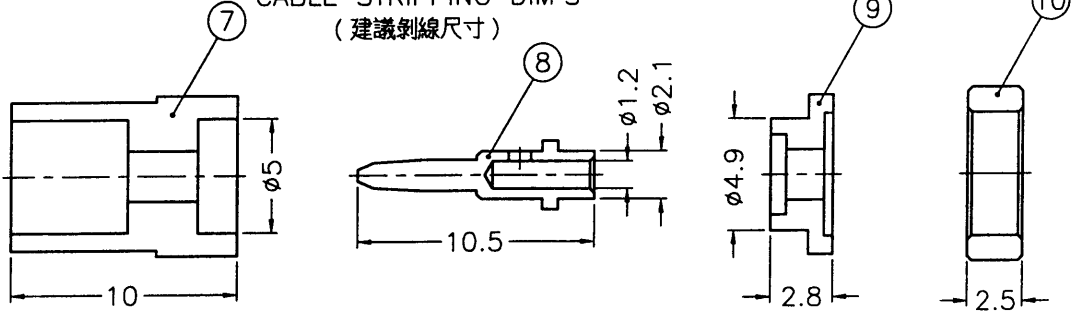

- NOTES: FINISH (PLATING THICKNESS IN MICRO-INCHES)
- BRASS PER QQ-B-626
  - BRASS PER QQ-B-613
  - NICKEL PL. 100 MIN. THICK OVER COPPER STRIKE
  - GOLD PL. 3 MIN. THICK OVER NICKEL PL. 100 MIN. THICK OVER COPPER STRIKE

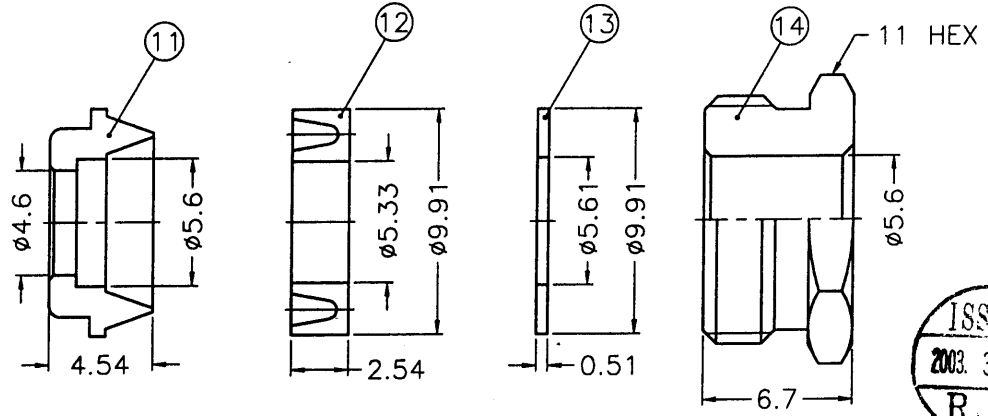

14	HEX NUT	NOTE 1	NOTE 3	1	B5200-14-11/56
13	WASHER	NOTE 2	NOTE 3	1	82-946-28
12	GASKET	SILICONE	RED	1	82-1536-5
11	BRAID CLAMP	NOTE 1	NOTE 3	1	BC00AAR01A
10	RING	NOTE 1	NOTE 3	1	B5200-10
9	INSULATOR	DELTRIN	NATURAL	1	B5200-9
8	CONTACT PIN	NOTE 1	NOTE 4	1	B5200-8-21/12
7	INSULATOR	DELTRIN	NATURAL	1	B5200-7-50
6	WASHER	NOTE 2	NOTE 3	1	WS-128/9X08
5	RING	DELTRIN	NATURAL	1	T50000-6-A
4	RETAINER RING	NOTE 1	NOTE 3	1	B50000-5
3	GASKET	RUBBER	RED	1	GS-105/8X15
2	BODY	NOTE 1	NOTE 3	1	B5200-2-A
1	SHELL	NOTE 1	NOTE 3	1	T50000-1-B
NO.	DESCRIPTION	MATERIAL	FINISH	Q'TY	DRAWING NO.

DIMENSIONS ARE IN MILLIMETERS				PART NO.	
UNLESS OTHERWISE SPECIFIED TOLERANCES 0.5-6 = ±0.2 6-30 = ±0.4 30-120 = ±0.6 120-315 = ±1 315-1000 = ±1.6 1000-2000 = ±2.4				APPROVED	DATE
				CHECKED	DATE
				DRAWN	DATE
				FILE NO.	F:\DWG\T\1141A1\58U-50\ND3G

<b>Amphenol</b>	
Danbury, CT, USA - Tainan, Taiwan - Shenzhen, China	
TITLE	TNC CLAMP PLUG (FOR RG-58C/U, 58/U, 142A/U, 223/U)
DRAWING NO.	T1141A1-ND3G-58U-50
ITEM NO.	021141AAB58ND5F

7 PD DR 193228