

REVISIONS		
ISS	ZONE	DESCRIPTION\PER REQUEST\DATE

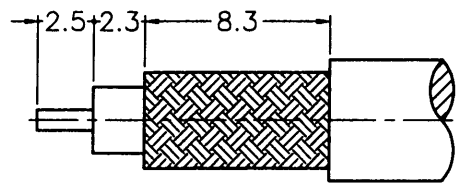

RECOMMENDED
CABLE STRIPPING DIM'S
(建議剝線尺寸)

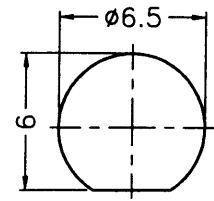

RECOMMENDED
MOUNTING HOLE
(建議架設孔)

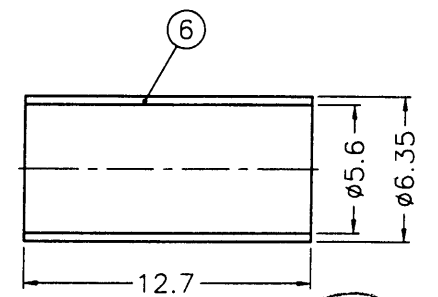
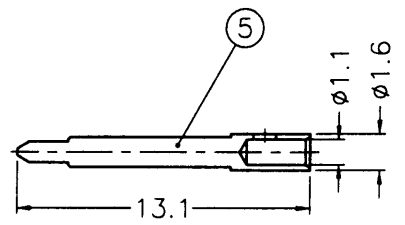
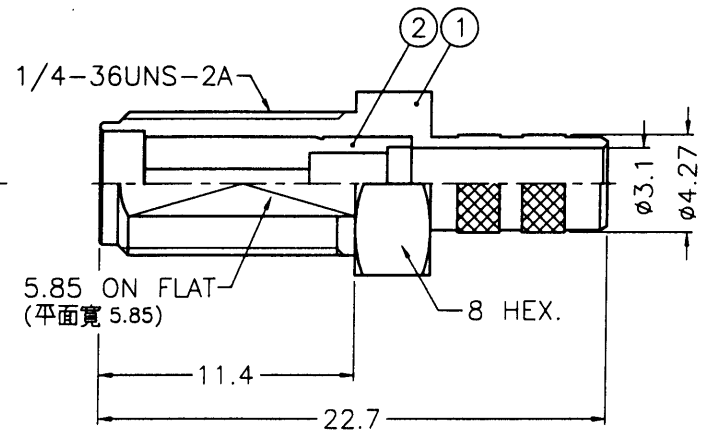
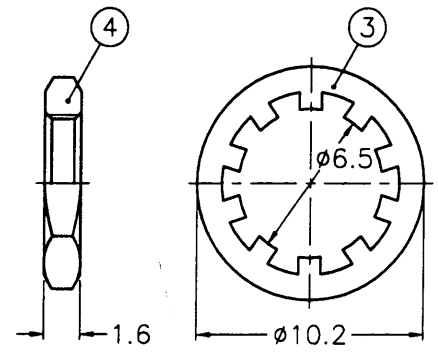

NOTES: FINISH (PLATING THICKNESS IN MICRO-INCHES)
 1. BRASS PER QQ-8-626
 2. BRASS PER QQ-8-613
 3. GOLD PL. 3 MIN. THICK OVER NICKEL PL. 100 MIN. THICK OVER COPPER STRIKE
 4. GOLD PL. 50 MIN. THICK OVER NICKEL PL. 100 MIN. THICK OVER COPPER STRIKE
 5. TEFLON MIL-P-19468
 6. JIS H 3250, C 2600

REMARK : 1. BETWEEN NO.1 AND NO.2 MUST WITHSTAND A 6 LBS MIN. SEPARATED FORCE.
 (1. 零件 1 及零件 2 至少須承受 6 磅的脫離力量)

1. CRIMPED FERRULE
HEX. CRIMP SIZE .213"
2. CONTACT PIN TO SOLDER
3. MAX. PANEL THICKNESS=3.2mm

NO.	DESCRIPTION	MATERIAL	FINISH	Q'TY	DRAWING NO.	SCALE	3/1	ISSUE	A	FILE NO.	PART NO.	TITLE
6	FERRULE	NOTE 6	NOTE 3	1	FR-635/56X127	DIMENSIONS ARE IN MILLIMETERS					Amphenol - Kai Jack TAINAN TAIWAN TITLE SMA REVERSE POLARITY BULKHEAD CRIMP JACK (FOR RG-55/U,142A/U,223/U,400/U) DRAWING NO. KJ-RSMA6411A1-3GT50G-223U-50 ITEM NO. 616411AAD26GA5F	
5	CONTACT PIN	NOTE 1	NOTE 4	1	RSMA6111A2-3-16/11	UNLESS OTHERWISE SPECIFIED TOLERANCES				APPROVED		
4	HEX NUT	NOTE 1	NOTE 3	1	HN8-1/4-36X16	0.5-6 = ±0.2 6-30 = ±0.4 30-120 = ±0.6 120-315 = ±1 315-1000 = ±1.6 1000-2000 = ±2.4				CHECKED		
3	LOCK WASHER	NOTE 2	NOTE 3	1	LW-102/65X05					DRAWN		
2	INSULATOR	NOTE 5	NATURAL	1	SMA7000-2T-50					DATE 07-05-02'		
1	BODY	NOTE 1	NOTE 3	1	SMA7400-1-427/31-C					DATE 07-05-02'		
NO.	DESCRIPTION	MATERIAL	FINISH	Q'TY	DRAWING NO.	SCALE	3/1	ISSUE	A	FILE NO.		

Jackey
Jackey
Jackey